



Druckstufe: PN 40
Baulänge: DIN EN558-1 GR1
Flanschform: gemäß EN 1092-1, Form B1
Gehäuse: Stahlguss (1.0619)
Dichtungsart: metallisch
Bauform nach DIN EN 13709
Werkstoffe buntmetallfrei
Durchflussrichtung ist stets unter dem Kegel

Zulassungen/Prüfungen: optional TA-Luft Zulassung

Nennweite	Druckstufe	Artikelnummer
DN 15	PN 40	RV-261-15
DN 20	PN 40	RV-261-20
DN 25	PN 40	RV-261-25
DN 32	PN 40	RV-261-32
DN 40	PN 40	RV-261-40
DN 50	PN 40	RV-261-50
DN 65	PN 40	RV-261-65
DN 80	PN 40	RV-261-80
DN 100	PN 40	RV-261-100
DN 125	PN 40	RV-261-125
DN 150	PN 40	RV-261-150
DN 200	PN 40	RV-261-200
DN 250	PN 40	RV-261-250

-10°C	zulässige Betriebsdrücke (bar) bei °C	
	neutrale Flüssigkeiten	neutrale Gase
+120°C	40	40
+200°C	35	35
+400°C	21	21

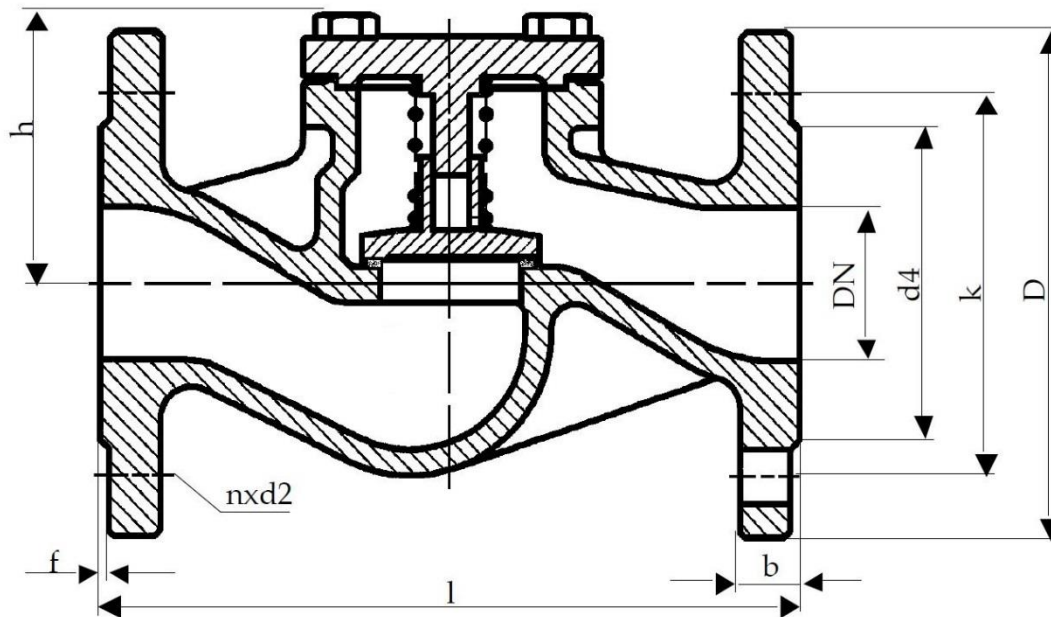

Ø DN (mm)	D	k	d4	l	h	n	d2	b	f	kg
15	95	65	45	130	90	4	14	16	2	3,0
20	105	75	58	150	75	4	14	18	2	4,0
25	115	85	68	160	90	4	14	18	2	4,5
32	140	100	78	180	85	4	18	18	2	6,0
40	150	110	88	200	95	4	18	18	3	8,0
50	165	125	102	230	105	4	18	20	3	10,5
65	185	145	122	290	105	8	18	22	3	16,0
80	200	160	138	310	135	8	18	24	3	21,0
100	235	190	162	350	180	8	22	24	3	35,0
125	270	220	188	400	210	8	26	26	3	63,0
150	300	250	218	480	220	8	26	28	3	74,0
200	375	320	285	600	270	12	30	34	3	128,0
250	450	385	345	730	-	12	33	38	3	181,0

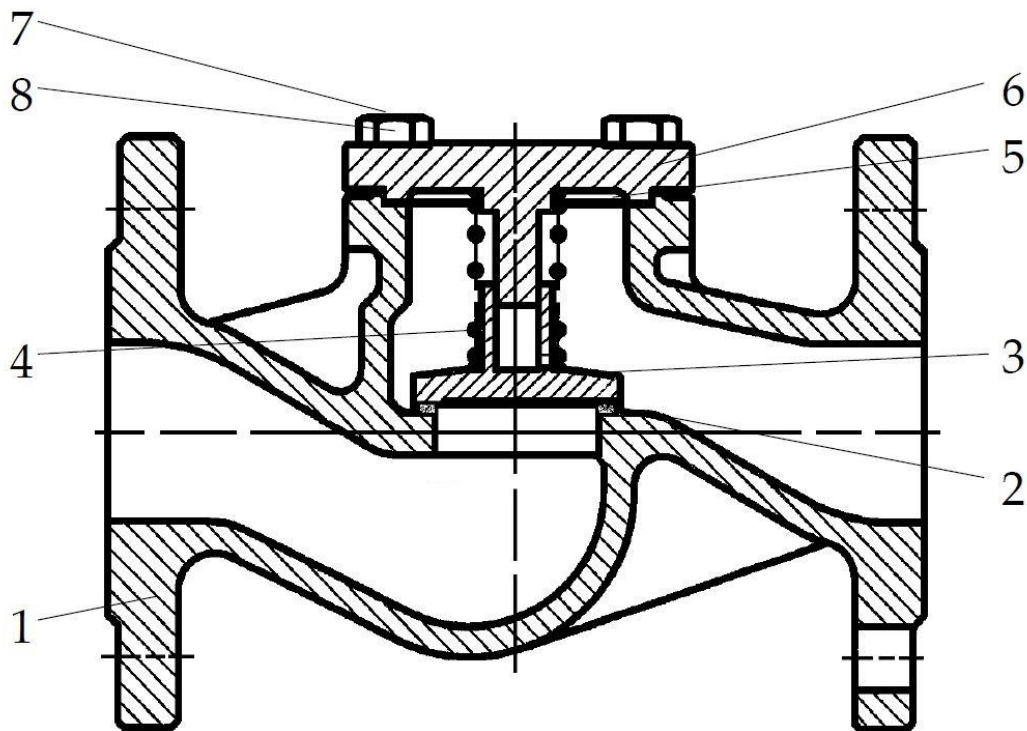

Nummer	Bezeichnung	Werkstoff
1	Gehäuse	Stahl GP240GH+N / 1.0619
2	Dichtfläche	X20Cr13 / 1.4021
3	Kegel	X20Cr13 / 1.4021
4	Feder	X5CrNi18-10 / 1.4301
5	Dichtung	Graphit / Metall
6	Deckel	Stahl GP240GH+N / 1.0619
7	Stiftschraube	24CrMo5 / 1.7258
8	Skt.-Mutter	Ck35 / 1.1181